

After Power ON, the Status LED on a Clevertest Plus enabled fitting will display a rapid Green or Red flashing for a period up to 2 minutes.

Zoneworks, HIVE and DATA Monitored Options

Fittings with part numbers -ZW, -HVG, -DATA are fitted with Zoneworks communications modules (nodes). These fittings are monitored using either Powerline Carrier Technology that utilize the power cable to provide data communication, RF transceiver modules operating in the ISM band or a dedicated data cable to/from data routers installed on a dedicated data trunk connected to a central Server (can also be connected via Ethernet/Internet/Fibre). Zoneworks software on the server is used to monitor, coordinate testing and collate test data from each fitting. Zoneworks Fittings can be commissioned by a single push of the test switch or by scanning the supplied barcode. The LED Test Switch indicator provides a multifunction indication of the status of the fitting during testing and normal operation:

| Option | State | LED Operation |
|---------------|---|--|
| ZW, HVG, DATA | Commissioned | LED on Solid (Green) |
| ZW, DATA | Un-commissioned | Batt plugged-in: yellow 1s, green 1s |
| | | Batt unplugged: red 1s, off 1s |
| HVG | Un-commissioned With network connectivity | Batt plugged-in: yellow 1s, green 1s |
| | | Batt unplugged: red 1s, off 1s |
| HVG | Un-commissioned Without network connectivity | Batt plugged-in: yellow 250mS, green 250mS, yellow 250mS, green 250mS, green 1s |
| | | Batt unplugged: red 250mS, off 250mS, red 250mS, off 250mS, off 1s |
| ZW, DATA | Emergency Light Test In Progress | LED flashes at yellow 5s , Off 1s |
| HVG | Emergency Light Test In Progress | LED flashes at yellow 1s , Off 1s |

In the case of the DATA version a 2-way “figure 8” cable and terminal block facilitates the connection to the DATA network via a multi-drop bus (daisy chain connection). For further information of installation of a Zoneworks system, please refer to the Zoneworks Users Guide and Commissioning Guide (incl. DATA version)

DALI EM Option

Luminaires with part numbers having -DALI are fitted with DALI modules (nodes) that facilitate connection and integration to 3rd Party Lighting Control Systems. Before installing the -DALI fitting please confirm that the Lighting Control System has the capability to monitor DALI Emergency Luminaires. The -DALI fitting will be addressed and configured into the control system by the Lighting Control System Commissioning Technicians and not Clevertronics

| State | LED Operation |
|----------------------------------|--|
| Commissioned/ Un-commissioned | LED on Solid (Green) |
| Emergency Light Test in progress | LED flashes at 1s On (Yellow) & 1s Off |
| “IDENTIFY COMMAND” | Lamp and Status LED Flash for 30 seconds |

A 2-way “figure 8” cable and terminal block facilitates the connection to the DALI network OR a 5/6way “structured wiring system” lead and plug facilitating the power and DALI connection. DALI connections are marked as Da Da.



CLP™ ARGONAUT Weatherproof Wall Light

Installation & Maintenance Instruction Leaflet

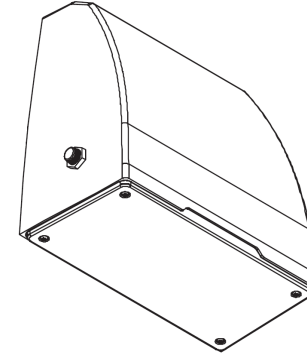

NOTE: Standard product codes with this symbol  are enabled with Clevertest Plus capability. Please refer to the operation guide supplied with the product for details.



Australia (Head Office)
 Website: www.clevertronics.com.au
 Email: info@clevertronics.com.au
 Phone: +61 3 9559 2700
 Fax: +61 3 9559 2799

UK OFFICE
 Website: www.clevertronics.co.uk
 362 Stockley Close
 West Drayton UB7 9BL
 Phone: 01895 430 255

Models:

ARGOWALL-LP- xx-yy

Testing:

Manual Test xx = Blank
 Zoneworks HIVE xx = HVG
 DALI Registered. xx = DALI

Options:

Colour default RAL7016 yy = blank
 Colour Custom yy = colour code



Spare Parts:

1550290 Replacement Battery
 8050219 Replacement Emergency/240V LED Board
 UKM02370310001 Replacement Emergency Driver
 UKM02870330001 Replacement Emergency Driver (HVG Only)
 1330153 Replacement 240V Driver

Important:

It is illegal for anyone, except for a licensed electrician to install or maintain this product. Before installation, ensure that the electricity supply has been switched off and isolated. Installation must be carried out in accordance with the relevant British Standards.

Photocell (Daylight Sensor):

ARGOWALL luminaires are fitted with an energy saving photocell for detecting day/night light levels. When ambient light is 10-20lx the photocell will turn ON the main light when Lsw is powered. When ambient light is 30-80lx the photocell will turn OFF the main light when Lsw is powered. To bypass this function and allow light on during the day, fit link across PC1 and PC2 terminals. Emergency light function is NOT affected by the photocell operation.

Installation:

The ARGOWALL is a wall mount fitting. The luminaire can be attached directly to any solid surface using the mounting plate supplied. Please follow the steps below to install the luminaire:

- Mains power must be switched off during and Installation or Maintenance.
- Drill 3 x suitable holes for mounting.
- Fix mounting plate to wall using suitable fixings for the weight of the product.
- Loosen the four screws holding the LED panel on and lower gear tray LED panel.
- Route the 240VAC supply cable through the entry hole.
- Seal the 240VAC supply cable entry hole appropriately using a suitable compound such as silicone.
- Connect the 240VAC supply (⊕, Lsw, Lem, N) to the terminal block of the gear tray.
- To disable the PhotoCell (Daylight) sensor, add a link between terminal block labelled PC1 PC2.
- Slide gear tray back into luminaire and carefully tighten the four screws to secure the gear tray LED panel to the housing. Ensure that the seal has been aligned to ensure IP rating is achieved.
- Fit Luminaire onto mounting plate and secure the top mounting screw and insert the screw cap into housing.
- If the CTP capabilities are activated, please affix the CTP status label to a visible surface and Four Segment Marking on the product will include an "F" in third segment block.

Dimensions:

Mounting hole locations

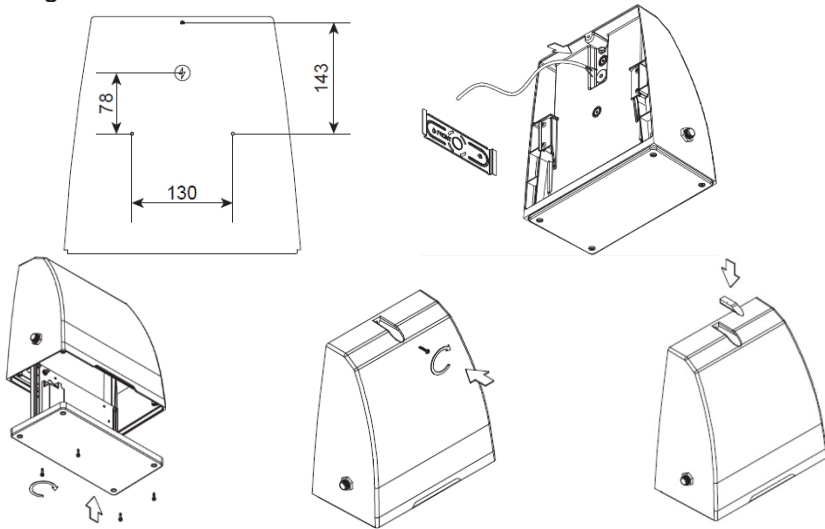

Note:

This luminaire (with reinforced insulation between control/LED terminal and AC supply) contains non-user replaceable light source and battery - to be replaced (if required, refer installation instructions for battery replacement) by Clevertronics service personnel/agents or a registered electrician.

Battery Replacement:

1. Prior to any work, isolate the power to the luminaire that requires battery replacement.
2. Loosen the four screws holding the LED panel on and lower gear tray LED panel.
3. Disconnect the battery connector from Emergency.
4. Replace battery and reconnect to Emergency Driver.
5. Slide gear tray back into luminaire and carefully tighten the four screws to secure the gear tray LED panel to the housing. Ensure that the seal has been aligned to ensure IP rating is achieved.

Lamp Replacement:

1. Prior to any work, isolate the power to the luminaire that requires Lamp replacement.
2. Loosen the four screws holding the LED Panel/gear tray.
3. Remove 3 screws on the back of the LED panel to remove diffuser.
4. Disconnect Lamp connections from LED panel.
5. Remove screws holding LED panel and replace LED panel.
6. Re-assembly following process in reverse.
7. Slide gear tray back into luminaire and carefully tighten the four screws to secure the gear tray LED panel to the housing. Ensure that the seal has been aligned to ensure IP rating is achieved.

Testing Procedure:

When the unit is connected to the un-switched active, it must be allowed to charge the battery for at least 24 hours. The emergency lamp only illuminates during a power fail. Conduct the following tests:

- The emergency lamp must illuminate for at least 180 min after disconnection from the mains. If the unit fails to illuminate for the requisite time, remedial action must be taken to repair the situation and once completed, the unit must pass a subsequent test.
- Press and hold Test Button or switch Off Mains Supply, check that the emergency lamp is On.
- Release the Test Button or Switch On Mains Supply, check that the emergency lamp is Off (Non-maintained operation).

Trouble Shooting:

Below are a list of common problems and their possible causes.

Fault: The Green LED Test Switch indicator is not illuminated.

Check: A.C. is connected and is turned on.
Battery is connected.
Test Switch for damage.

Fault: Lamp does not illuminate in emergency mode.

Check: A.C. is connected.
Lamp is correctly inserted.
Battery is connected.

Fault: Lamp illuminates in emergency mode, but only stays on for a short period.

Check: Battery has been allowed to charge for at least 24 hours.
Battery for damage.

Caution:

On many building sites, power circuits may be cut off in an uncontrolled and repetitive basis during construction. As a result, any Exit & Emergency Units, on these circuits, will have their batteries discharged or "cycled". The Li-ion battery in the Exit & Emergency Unit has been selected to give excellent long life performance in a controlled IEC 60598-2-22 testing environment. Excessive battery cycling will reduce through-life performance and may lead to premature battery failure. Battery warranty claims, as a result of such abuse, are specifically EXCLUDED from Clevertronics warranty terms.

Warranty:

For Product Warranty information and Terms and Conditions of Sales please refer to our website <https://clevertronics.co.uk/product-warranty-statement/>